

CAPACITY  
MATCHED

RUGGED, INDOOR/  
OUTDOOR DESIGN

READY TO  
INSTALL

TOTAL LOCAL  
SUPPORT

# ENVIRONMENTAL CONTROL



## Industrial Cooling Series

# FULLY SELF-CONTAINED AIR CONDITIONING WITH INDUSTRIAL DURABILITY

- **RUGGED INDUSTRIAL DESIGN.** BUILT WITH HIGH QUALITY, DURABLE COMPONENTS. OPTIONAL PROTECTIVE COATINGS PROVIDE ADDITIONAL CORROSION RESISTANCE IN HARSH ENVIRONMENTS.
- **SELF-CONTAINED PACKAGE.** ALL COOLING, REHEAT, HUMIDIFICATION AND CONTROL FUNCTIONS ARE CONTAINED IN THE ICS PACKAGE — NO REFITTING IS REQUIRED.
- **MODELED ON FIELD-PROVEN OPERATION.** BASED ON A LIEBERT DESIGN PROVEN IN MORE THAN 100,000 INSTALLED SITES.
- **RELIABLE OPERATION.** TWO SEMI-HERMETIC COMPRESSORS SHARE THE COOLING LOAD. TOTALLY INDEPENDENT MOTORS AND BLOWERS ENSURE CONTINUOUS OPERATION.
- **EASY SERVICING.** CONVENIENT ACCESS FOR FIELD SERVICING. SPARE PARTS READILY AVAILABLE THROUGH YOUR LIEBERT REPRESENTATIVE AND THE LIEBERT CUSTOMER SERVICE AND SUPPORT NETWORK.
- **OPTIONAL ADVANCED MONITORING AND CONTROL.**



ISO 9000  
CERTIFIED  
COMPANY

## INDUSTRIAL COOLING



The Industrial Cooling Series is factory tested as a complete system.



An adjustable fan base pulls out for flexibility and serviceability.



The semi-hermetic compressors are unequalled for ruggedness and reliability.

## CLOSE-CONTROL AIR CONDITIONING BUILT INDUSTRIAL TOUGH

Your process control equipment has to be tough in order to operate under harsh conditions, and the air conditioner maintaining the environment must match this durability. The Liebert ICS is designed for the physical needs of industrial sites, with rugged and serviceable components to ensure continuous operation.

ICS also has the intelligence that microprocessor technology provides. This advanced system provides close temperature and humidity control, improving the operating conditions for your electronic process control equipment.

**Cooling coil.** The Liebert manufactured A-Frame coil (slab coil on 60 ton models) is constructed of copper tubes and aluminum fins, and is provided with a rust-proof stainless steel drain pan. The condensate drain line is internally trapped to simplify installation. The large surface area of the coil allows greater cooling capabilities, and the split-coil design provides greater control during dehumidification.

**Semi-hermetic compressors.** Two independently-circuited cast-iron semi-hermetic compressors are the industry standard for rugged operation. The heavy, sealed cast-iron cases protect the assembly from dust, moisture and other contaminants. The field-serviceable design saves time in maintenance.

**Stainless steel electric reheat.** The fin-tubular reheat operates in three equal stages, providing greater control of air temperature. The low watt density, electrically enclosed elements are surrounded by the stainless steel tube and fins, reducing sheath temperatures that could cause ionization of dust particles.

**Steam-generating humidifier.** The microprocessor-controlled humidification system adds clean, pure steam to the coil bypass air when humidity is required. The disposable canister, complete with supply and drain valves, is factory installed and located out of the air stream. It is also easily maintained—an indicator light on the unit monitor panel signals when the canister should be changed. Automatic humidifier flush cycles are tailored to your site needs to lengthen service life.

**Removable fan section.** Two epoxy-coated Class II fans are standard in all ICS units. These double width, double inlet blowers draw air across the cooling coil for uniform air distribution and effective coil performance. For greater reliability in operation, each fan is driven by a separate Totally Enclosed Fan Cooled (TEFC) motor. The entire assembly is statically and dynamically balanced to less than 2 mils, and is mounted on a front removable slide base for easy service.

# INDUSTRIAL COOLING

## BUILT-IN RESISTANCE TO CORROSIVE CONDITIONS.

**Close-control operation.** A field-proven microprocessor is the “brains” of the ICS operation. As a standard feature, this system tracks and displays temperature and humidity, maintaining the environment within your control requirements. The microprocessor also controls functions such as humidifier flush cycles, alarm parameters and manual compressor sequencing, ensuring reliable and accurate operation. Battery back-up is included to maintain your control setpoints in the event of power failure.

ICS is also available with an optional control system which provides enhancements such as diagnostics and automated compressor sequencing, as well as expanded monitored parameters. This system is available in your choice of control: fuzzy logic, proportional, or tunable PID.

**System monitoring and alarms.** The standard monitoring system identifies normal operating status— heating, cooling, dehumidification or humidification — on a lighted display. The system will activate audible and visual alarms for extremes in temperature or humidity, loss of air flow, and to indicate a need to service air filters. A “local” alarm can be customized to indicate high head pressure or optional water leak detection.

**Monitoring options.** Liebert offers several monitoring options for your site needs, including remote monitoring with the Liebert SiteScan; remote autochangeover for up to eight ICS units; point and zone water detection systems; and monitors for dry contact points. Liebert also offers site management interface to your existing system through direct analog or RS232.

Corrosion resistant coatings are available as standard or optional features on many system components, allowing ICS to fit the needs of individual sites.

System Component	Protective Element	Availability
Cabinet and Frame	Scratch-resistant two-component epoxy paint. The industry standard for durability.	Standard
Fans	Epoxy coating. Corrosion resistant paint extends component life.	Standard
Finned Tubular Reheat	Stainless steel reheat. Provides longer service life in harsh environments.	Standard
Drain Pan	Stainless steel. Low maintenance, corrosion resistant.	Standard
Gasketing	Closed cell gasketing. Provides an air tight seal to prevent infiltration of corrosive, untreated air.	Optional
A-Frame Coil	Phenolic coating. Dipped and baked for extra protection in corrosive conditions.	Optional
Water Cooled Condensers	90/10 Cu-Ni tubes. Marine specification copper and nickel construction.  Stainless steel tubes. Rustproof design for harsh water conditions.	Optional
Air Cooled Condensers	Phenolic coated coils. Additional protection against corrosion.	Optional



Standard Control/  
Monitoring System



Zone Water  
Detection System



Optional Control/  
Monitoring System

# FLEXIBILITY TO MEET YOUR APPLICATION NEEDS

Many industrial sites and other special applications require a customized air conditioning system to meet the demands of corrosive environments, space restrictions or stringent design specifications. The Liebert Industrial Cooling Series has a long list of available features to meet your site requirements. For more extensive tailoring, Liebert engineers can work with you to design a system to match your needs.

## SELECTABLE SYSTEM FEATURES

### Chilled Water Models

- Complete line of chilled water models. Consult factory for details.

### Water Cooled Condensers

- Marine-grade 90/10 copper-nickel
- Stainless steel
- Common supply and return
- Separate supply and return for each water cooled condenser circuit
- Two-way water regulating valves
- Three-way water regulating valves
- 300 PSI rating on water cooled systems
- Water-flow switch

### Humidifier

- Increased humidifier capacity
- Steam distributor humidifier to utilize building steam system

### Reheat

- Increased reheat capacity up to twice the standard capacity

### Blower Configurations

- Top discharge
- Rear, horizontal discharge
- Front air return, rear return, bottom return
- Upsized motors for high external static pressure requirements
- High efficiency fan motors, severe duty motors

### Other Selections

- Cut down frame for easy installation
- Control and alarm modifications
- Epoxy painted piping
- Customized refrigeration systems and specially designed and constructed coils

## Typical Duct Arrangements.

The Industrial Cooling Series is designed for ducted applications, using any of the following typical duct arrangements. Back-draft dampers are recommended to facilitate service.

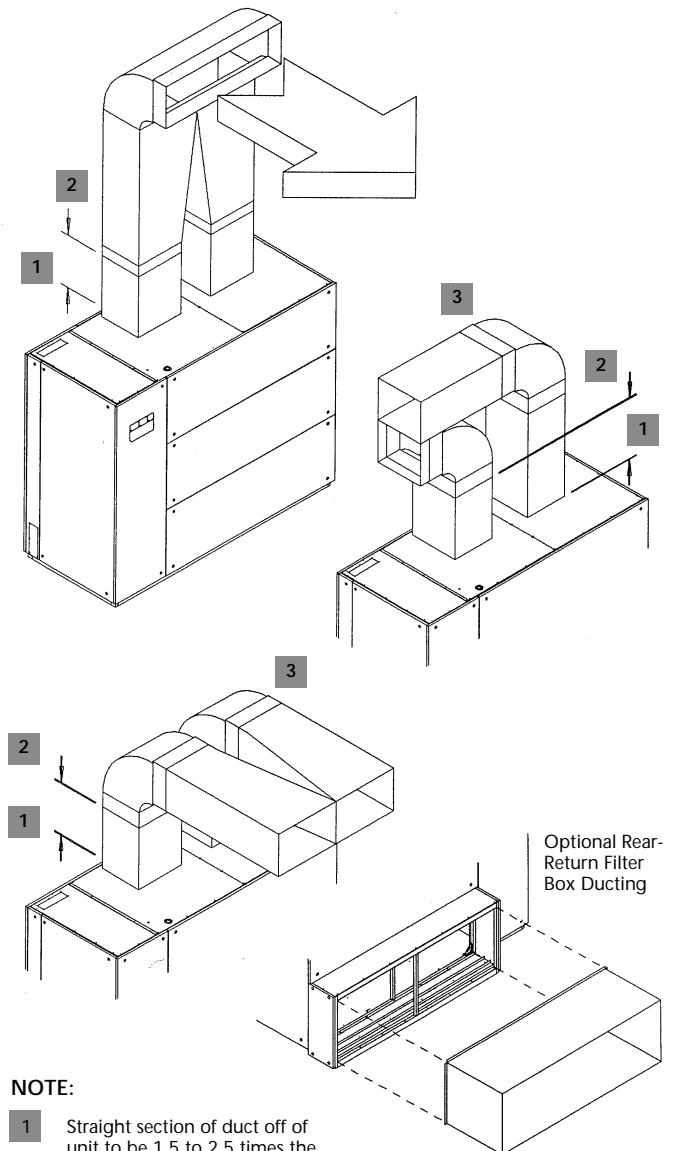

### NOTE:

- 1 Straight section of duct off of unit to be 1.5 to 2.5 times the longest blower discharge dimension. Follow standard practices on all duct work.
- 2 Recommended damper location.
- 3 Alternate damper location.

# Dimensional Data

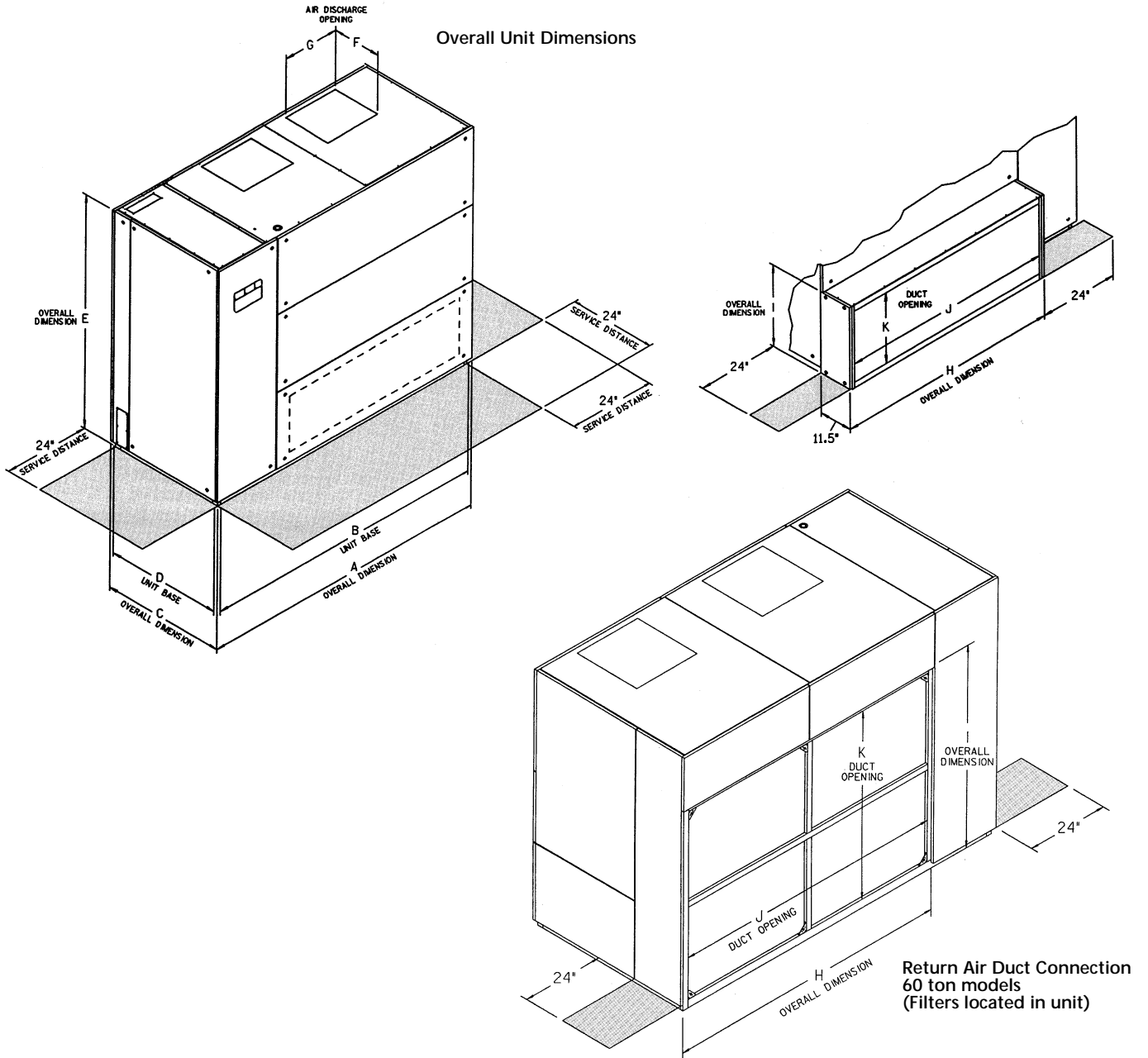

Dimensional Data Inches (mm)	Model					
	130W, 126A	200W, 187A	250W, 239A	390W, 375A	500W, 475A	690W, 650A
A	76 (1930)	99 (2515)	99 (2515)	128 (3251)	128 (3251)	128 (3251)
B	74 (1880)	97 (2464)	97 (2464)	126 (3200)	126 (3200)	126 (3200)
C	42 (1067)	42 (1067)	42 (1067)	50 (1270)	50 (1270)	62 (1575)
D	40 (1016)	40 (1016)	40 (1016)	48 (1219)	48 (1219)	60 (1525)
E	80 (2032)	80 (2032)	80 (2032)	90 (2286)	90 (2286)	90 (2286)
F	11 <sup>1</sup> / <sub>2</sub> (292)	13 <sup>5</sup> / <sub>8</sub> (346)	13 <sup>5</sup> / <sub>8</sub> (346)	19 (483)	19 (483)	24 <sup>3</sup> / <sub>4</sub> (629)
G	10 <sup>5</sup> / <sub>8</sub> (270)	12 <sup>3</sup> / <sub>8</sub> (314)	15 <sup>3</sup> / <sub>4</sub> (400)	17 <sup>1</sup> / <sub>2</sub> (445)	22 (559)	24 <sup>3</sup> / <sub>4</sub> (629)
H	53 <sup>1</sup> / <sub>8</sub> (1350)	76 <sup>1</sup> / <sub>8</sub> (1934)	76 <sup>1</sup> / <sub>8</sub> (1934)	102 <sup>3</sup> / <sub>4</sub> (2611)	102 <sup>3</sup> / <sub>4</sub> (2611)	102 <sup>3</sup> / <sub>4</sub> (2611)
I	28 (711)	28 (711)	28 (711)	57 (1478)	57 (1478)	71 (1804)
J	49 <sup>1</sup> / <sub>8</sub> (1248)	72 <sup>1</sup> / <sub>8</sub> (1832)	72 <sup>1</sup> / <sub>8</sub> (1832)	98 <sup>3</sup> / <sub>4</sub> (2508)	98 <sup>3</sup> / <sub>4</sub> (2508)	98 <sup>3</sup> / <sub>4</sub> (2508)
K	24 (610)	24 (610)	24 (610)	51 (1295)	51 (1295)	66 (1677)

NOTE: For unit weights, see General Data Tables on page 6.

60 Hz AIR COOLED MODELS

Model Number	UP 126A	UP 187A	UP 239A	UP 375A	UP 475A	UP 650A
<b>Net Capacity Btu/h (kW)</b>						
<b>80 F DB, 67 F WB, 50% RH (26.7 C DB, 19.4 C WB)</b>						
Total	130,400(38.2)	184,800(54.1)	240,300(70.4)	373,400(109.5)	447,800(131.2)	650,400(190.5)
Sensible	102,000(29.9)	148,100(43.4)	194,700(59.0)	292,400(85.7)	367,500(107.7)	530,100(155.3)
<b>75 F DB, 62.5 F WB, 50% RH (23.9 C DB, 16.9 C WB)</b>						
Total	121,400(35.6)	172,200(50.9)	223,500(65.5)	347,100(101.8)	417,900(122.4)	608,600(178.3)
Sensible	99,000(29.0)	143,600(42.1)	188,600(55.2)	283,500(83.0)	356,200(104.3)	514,800(150.8)
<b>72 F DB, 60 F WB, 50% RH (22.2 C DB, 15.6 C WB)</b>						
Total	116,100(34.0)	165,000(48.3)	213,800(62.6)	333,000(97.6)	401,600(117.6)	586,400(171.8)
Sensible	97,000(28.4)	140,800(41.2)	184,600(54.1)	278,200(81.5)	349,500(102.4)	505,800(148.2)

60 Hz WATER COOLED MODELS

Model Number	UP 130W	UP 200W	UP 250W	UP 390W	UP 500W	UP 690W
<b>Net Capacity Btu/h (kW)</b>						
<b>80 F DB, 67 F WB, 50% RH (26.7 C DB, 19.4 C WB)</b>						
Total	138,600(40.6)	200,800(58.8)	256,600(75.2)	396,900(116.3)	471,100(138.0)	692,100(202.8)
Sensible	105,100(30.8)	154,100(45.2)	200,700(58.8)	301,200(88.3)	376,000(110.2)	545,600(159.9)
<b>75 F DB, 62.5 F WB, 50% RH (23.9 C DB, 16.9 C WB)</b>						
Total	127,600(37.4)	185,400(54.3)	235,800(69.1)	366,700(107.5)	435,800(127.7)	641,400(187.9)
Sensible	101,500(29.7)	149,000(43.7)	193,500(56.7)	291,500(84.5)	363,400(106.5)	528,000(154.7)
<b>72 F DB, 60 F WB, 50% RH (22.2 C DB, 15.6 C WB)</b>						
Total	121,500(35.6)	176,700(51.8)	224,400(65.8)	349,300(102.4)	416,500(122.0)	614,300(180.0)
Sensible	99,300(29.1)	145,800(42.7)	189,100(55.4)	285,200(83.6)	355,800(104.3)	517,700(151.7)

60 Hz GLYCOL COOLED MODELS

Model Number	UP 130W	UP 200W	UP 250W	UP 390W	UP 500W	UP 690W
<b>Net Capacity Btu/h (kW) (using 40% Ethylene Glycol)</b>						
<b>80 F DB, 67 F WB, 50% RH (26.7 C DB, 19.4 C WB)</b>						
Total	121,900(35.7)	179,500(52.6)	228,300(66.9)	359,100(105.3)	418,000(122.5)	611,800(179.3)
Sensible	98,800(29.0)	146,100(42.8)	190,300(55.8)	287,100(84.1)	356,700(104.5)	516,000(151.2)
<b>75 F DB, 62.5 F WB, 50% RH (23.9 C DB, 16.9 C WB)</b>						
Total	113,600(33.3)	167,500(49.1)	212,700(62.3)	334,900(98.2)	392,200(115.0)	575,700(168.7)
Sensible	95,800(28.1)	141,700(41.5)	184,200(54.0)	278,500(81.6)	346,100(101.4)	501,500(147.0)
<b>72 F DB, 60 F WB, 50% RH (22.2 C DB, 15.6 C WB)</b>						
Total	108,900(31.9)	160,600(47.1)	203,800(59.7)	322,100(94.4)	376,900(110.5)	554,000(162.4)
Sensible	93,900(27.5)	138,900(40.7)	180,400(52.9)	273,600(80.2)	339,200(99.4)	492,100(144.2)

60 Hz CHILLED WATER MODELS

Model Number	UP 158C	UP 216C	UP 234C	UP 379C	UP 431C	UP 545C	UP 600C
<b>Net Capacity Btu/h (kW) 45°F (7.2°C) Entering Water Temp</b>							
<b>80 F DB, 67 F WB, 50% RH (26.7 C DB, 19.4 C WB)</b>							
Total	158,400(46.4)	218,700(64.1)	234,900(68.8)	385,200(112.8)	434,200(127.2)	559,000(163.7)	603,600(176.8)
Sensible	113,500(33.2)	146,900(43.0)	169,400(49.6)	259,700(76.1)	312,500(91.5)	373,500(109.4)	433,800(127.1)
Flow Rate - GPM (L/s)	31.7(2.0)	43.7(2.8)	47(3.0)	77(4.9)	86.8(5.5)	111.7(7.0)	120.6(7.6)
Pressure Drop - Ft. of water (kPa)	19.7(58.7)	22.3(66.5)	19.1(56.9)	23.1(68.8)	27.4(81.7)	51.5(153.5)	25.9(77.2)
<b>75 F DB, 62.5 F WB, 50% RH (23.9 C DB, 16.9 C WB)</b>							
Total	118,000(34.6)	163,800(48.0)	175,500(51.4)	288,300(84.4)	322,200(94.4)	417,800(122.4)	447,700(131.1)
Sensible	97,500(28.6)	125,200(36.7)	145,700(42.7)	221,500(64.9)	268,200(78.6)	317,900(93.1)	372,100(109.0)
Flow Rate - GPM (L/s)	23.6(1.5)	32.7(2.1)	35.2(2.2)	57.6(3.6)	64.5(4.1)	83.4(5.3)	89.6(5.7)
Pressure Drop - Ft. of water (kPa)	11.4(34.0)	13.1(39.0)	11.1(33.1)	13.5(40.2)	15.8(47.1)	30.1(89.7)	15.0(44.7)
<b>72 F DB, 60 F WB, 50% RH (22.2 C DB, 15.6 C WB)</b>							
Total	96,600(28.3)	134,200(39.3)	144,000(42.2)	236,300(69.2)	263,100(77.1)	341,800(100.1)	365,500(107.1)
Sensible	88,200(25.8)	112,400(32.9)	132,100(38.7)	199,100(58.3)	242,800(71.1)	285,300(83.6)	336,800(98.7)
Flow Rate - GPM (L/s)	19.3(1.2)	26.8(1.7)	28.8(1.8)	47.2(3.0)	52.6(3.3)	68.3(4.3)	73.1(4.6)
Pressure Drop - Ft. of Water (kPa)	7.8(23.2)	9.1(27.1)	7.7(22.9)	9.4(28.0)	10.9(32.5)	20.9(62.3)	10.4(31.0)

# 50 Hz Data

## 50 Hz AIR COOLED MODELS

Model Number	UP 120A	UP 180A	UP 238A	UP 374A	UP 474A	UP 649A
<b>Net Capacity Btu/h (kW)</b>						
<b>80 F DB, 67 F WB, 50% RH (26.7 C DB, 19.4 C WB)</b>						
Total	131,200(38.5)	187,300(54.9)	235,600(69.1)	357,600(104.8)	451,600(132.4)	673,800(197.5)
Sensible	102,300(30.0)	149,000(43.7)	193,000(56.6)	286,600(84.0)	368,900(108.1)	538,800(157.9)
<b>75 F DB, 62.5 F WB, 50% RH (23.9 C DB, 16.9 C WB)</b>						
Total	122,000(35.8)	174,500(51.1)	219,900(64.5)	334,100(97.9)	421,900(123.7)	630,900(184.9)
Sensible	99,200(29.1)	144,600(42.4)	187,100(54.8)	278,200(81.5)	357,800(104.9)	523,800(153.5)
<b>72 F DB, 60 F WB, 50% RH (22.2 C DB, 15.6 C WB)</b>						
Total	116,700(34.2)	167,200(49.0)	210,600(61.7)	321,300(94.2)	406,000(119.0)	608,000(178.2)
Sensible	97,200(28.5)	141,700(41.5)	183,300(53.7)	273,300(80.1)	351,400(103.0)	515,000(150.9)

## 50 Hz WATER COOLED MODELS

Model Number	UP 129W	UP 198W	UP 249W	UP 389W	UP 499W	UP 689W
<b>Net Capacity Btu/h (kW)</b>						
<b>80 F DB, 67 F WB, 50% RH (26.7 C DB, 19.4 C WB)</b>						
Total	141,500(41.5)	212,100(62.2)	255,400(74.9)	388,000(113.7)	480,800(140.9)	735,300(215.5)
Sensible	106,200(31.1)	158,400(46.4)	200,300(58.7)	297,900(87.3)	379,600(111.3)	561,800(164.7)
<b>75 F DB, 62.5 F WB, 50% RH (23.9 C DB, 16.9 C WB)</b>						
Total	129,900(38.1)	194,800(57.1)	235,200(68.9)	359,500(105.4)	446,200(130.8)	684,600(200.6)
Sensible	102,500(30.0)	152,900(44.8)	193,300(56.7)	288,600(84.6)	367,600(107.7)	545,800(159.9)
<b>72 F DB, 60 F WB, 50% RH (22.2 C DB, 15.6 C WB)</b>						
Total	123,600(36.2)	185,900(54.5)	224,200(65.7)	342,000(100.2)	426,700(125.1)	652,400(191.2)
Sensible	100,200(29.4)	149,800(43.9)	189,000(55.4)	282,100(82.7)	360,100(105.5)	534,100(156.5)

## 50 Hz CHILLED WATER MODELS

Model Number	UP 158C	UP 216C	UP 234C	UP 379C	UP 431C	UP 545C	UP 600C
<b>Net Capacity Btu/h (kW) 45°F (7.2°C) Entering Water Temp</b>							
<b>80 F DB, 67 F WB, 50% RH (26.7 C DB, 19.4 C WB)</b>							
Total	158,400(46.4)	218,700(64.1)	234,900(68.8)	385,200(112.8)	434,200(127.2)	559,000(163.7)	603,600(176.8)
Sensible	113,500(33.2)	146,900(43.0)	169,400(49.6)	259,700(76.1)	312,500(91.5)	373,500(109.4)	433,800(127.1)
Flow Rate - GPM (L/s)	31.7(2.0)	43.7(2.8)	47(3.0)	77(4.9)	86.8(5.5)	111.7(7.0)	120.6(7.6)
Pressure Drop - Ft. of water (kPa)	19.7(58.7)	22.3(66.5)	19.1(56.9)	23.1(68.8)	27.4(81.7)	51.5(153.5)	25.9(77.2)
<b>75 F DB, 62.5 F WB, 50% RH (23.9 C DB, 16.9 C WB)</b>							
Total	118,000(34.6)	163,800(48.0)	175,500(51.4)	288,300(84.4)	322,200(94.4)	417,800(122.4)	447,700(131.1)
Sensible	97,500(28.6)	125,200(36.7)	145,700(42.7)	221,500(64.9)	268,200(78.6)	317,900(93.1)	372,100(109.0)
Flow Rate - GPM (L/s)	23.6(1.5)	32.7(2.1)	35.2(2.2)	57.6(3.6)	64.5(4.1)	83.4(5.3)	89.6(5.7)
Pressure Drop - Ft. of water (kPa)	11.4(34.0)	13.1(39.0)	11.1(33.1)	13.5(40.2)	15.8(47.1)	30.1(89.7)	15.0(44.7)
<b>72 F DB, 60 F WB, 50% RH (22.2 C DB, 15.6 C WB)</b>							
Total	96,600(28.3)	134,200(39.3)	144,000(42.2)	236,300(69.2)	263,100(77.1)	341,800(100.1)	365,500(107.1)
Sensible	88,200(25.8)	112,400(32.9)	132,100(38.7)	199,100(58.3)	242,800(71.1)	285,300(83.6)	336,800(98.7)
Flow Rate - GPM (L/s)	19.3(1.2)	26.8(1.7)	28.8(1.8)	47.2(3.0)	52.6(3.3)	68.3(4.3)	73.1(4.6)
Pressure Drop - Ft. of Water (kPa)	7.8(23.2)	9.1(27.1)	7.7(22.9)	9.4(28.0)	10.9(32.5)	20.9(62.3)	10.4(31.0)

## INDUSTRIAL COOLING

## GENERAL

- Designed and manufactured to include cooling, heating, humidifying, and dehumidifying functions in a single package
- Air-cooled, water-cooled, glycol-cooled, or chilled water configurations
- Upflow air discharge
- Factory tested as a system
- One-year warranty against defects in material and workmanship
- Optional 5-year compressor warranty

## Electrical

- 208, 230, 469, 575 Volts, 3-phase 60 Hz
- 380, 415 Volts, 50 Hz
- All component wiring enclosed in conduit
- Individually fused components
- Optional, factory mounted disconnect switch

## Water Cooled Condensers

- Cleanable shell and tube condensers
- Optional Marine-grade 90/10 copper-nickel condensers
- Optional Stainless Steel condensers
- Common supply and return piping, or option for separate supply and return
- Two-way regulating valves, optional three-way valves
- Optional 300 psi water side pressure rating
- Optional water-flow switch

## Air Cooled Condensers

- Optional Lee-temp head pressure control system, to -30°F
- Optional disconnect switch
- Optional phenolic coating on coils

## Humidity Control

- Microprocessor controlled
- Steam generating humidifier with disposable canister
- Option for increased humidifier capacity
- Automatic humidifier flush cycles
- Optional steam grid humidifier, to utilize existing building steam system

## Reheat

- Reheat controlled in three equal stages
- Stainless steel fin-tubular heating elements
- Option for increased reheat capacities, up to twice the standard capacity

## Blower

- Independently driven fans
- Top discharge
- Epoxy coating on fan wheel and housing
- Front accessible and removable fan section
- 200,000 hour, L-10 life pillow block bearings
- Optional rear, horizontal discharge
- Front, rear, or bottom air return
- Upsized motors and Class II blowers for high external static requirements
- Dual TEFC motors
- Optional high efficiency and severe duty motors

## Frame

- Heavy 14-gauge tubular steel frame
- 16 gauge steel panels, fully gasketed
- Two-component epoxy paint on panels
- Autophoretic painting process on frame
- 1", 1.5 lb. density neoprene coated fiber glass insulation
- Optional close-cell gasketing
- Optional cut-down frame

## Refrigeration System

- Two rugged, high efficiency, semihermetic compressors
- A-frame cooling coil (slab coil on 60 ton) with draw-through air arrangement
- Optional Phenolic coating for coils
- Optional 45% (BAG-5) silver solder on brazed joints
- Low sensible heat ratio design
- Epoxy painted piping
- Customized refrigeration systems and specially designed and constructed coils
- Water-side economizer coils
- Control and alarm modifications

## Air Filters

- 4"-20% (ASHRAE 52-76)
- Filter clog switch and alarm
- Optional efficiencies up to 85%

## Controls

- Microprocessor monitoring and controls
- Protective, conformal coating PCBs

LIEBERT CORPORATION

While every precaution has been taken to ensure accuracy and completeness in this manual, Liebert Corporation assumes no responsibility, and disclaims all liability for damages resulting from use of this information or for any errors or omissions.

© 1996 Liebert Corporation. All rights reserved throughout the world. Specifications subject to change without notice.

All names referred to are trademarks or registered trademarks of their respective owners.

SL-18500 (5/96)

Printed in U.S.A.